



ABATEX

[Experts em Divisórias]

A EMPRESA

Desde a sua fundação, em 1991, a Abatex vem crescendo ano após ano sempre sob os princípios de uma gestão ética e profissional. Assim fez-se referência, agregando valores aos propósitos de seus clientes.

Por inovar e investir constantemente em tecnologia, know how, pesquisas, equipamentos e recursos humanos, a empresa oferece o que há de melhor em divisórias.

O esmero nas etapas fabris, o comprometimento com o mercado e o respeito aos prazos acordados situam a Abatex, no contexto nacional, como uma das marcas de maior prestígio em seu setor.

Talento, eficiência e bom atendimento. Diferenciais que impressionam e conquistam.



O CONCEITO

Produzidas sob forma de sistemas – processo no qual o conjunto resultante é decorrente da combinação racional de partes coordenadas – as Divisórias Abatex apresentam design uniforme e harmonioso, com pequeno número de componentes. Tais características proporcionam flexibilidade construtiva, capacidade de atender as mais exigentes especificações, enriquecendo projetos de diversos estilos e características.











FLEXIBILIDADE E CRIATIVIDADE

Oferecendo liberdade na configuração dos módulos e várias combinações de acabamentos, as soluções são talhadas com características personalizadas, atendendo as necessidades peculiares de cada projeto e dos espaços que irão receber os elementos.

DESIGN

Moderna, esbelta, contemporânea. A forma quadrada, marcante da linha Theia é destacada pelos ângulos retos, linhas firmes e bem definidas, ressaltando arestas e planos.







02





SUSTENTABILIDADE

Por ser uma indústria de transformação, a Abatex tem como premissa, priorizar os fornecedores certificados e/ou que estejam engajados com a política de sustentabilidade. De sua parte, cuida para que todos os descartes e resíduos das matérias primas e insumos, sejam reciclados ou tenham seu destino final em empresas homologadas pelos órgãos competentes.







NORMATIZAÇÃO



Os produtos Abatex possuem o Certificado de Marca de Conformidade ABNT atendidos pela norma NBR 15141, que especifica as características físicas e dimensionais das divisórias modulares removíveis tipo piso teto para escritório, bem como estabelece os métodos para a determinação de sua resistência.

CERTIFICAÇÕES

Creditada e auditada periodicamente pela DQS, a Abatex possui o certificado da norma internacional ISO 9001, que garante a melhoria contínua dos produtos, serviços e processos.



THE INTERNATIONAL CERTIFICATION NETWORK



Deutsche Gesellschaft zur Zertifizierung von Managementsystemen mbH



THE INTERNATIONAL CERTIFICATION NETWORK







Board







CARACTERÍSTICAS GERAIS

Espessura de 85 mm
Modulação horizontal entre eixos de 1.250 mm (*)
Saque frontal e individual dos painéis
Estrutura interna e externa totalmente em alumínio
Painéis cegos duplos em aglomerado de 15 mm
Painéis em vidro único ou duplo Isolamento acústico
(em média de R_w 42dB a 49dB) (*), atestado (**)
Folhas de porta em madeira aglomerada maciça (*)
Dobradiças em alumínio com anéis de nylon
Fechaduras tipo chave/alavanca (*)
Passagem de fiação pelo interior da divisória ou
opcionalmente por rodapé eletrificável.

(*) Ou em conformidade com especificação

(**) Laudos do IPT disponíveis

MONTAGEM

A montagem é planejada, rápida e lógica. Os imprevistos são evitados com projetos detalhados, economizando substancialmente o tempo de instalação.







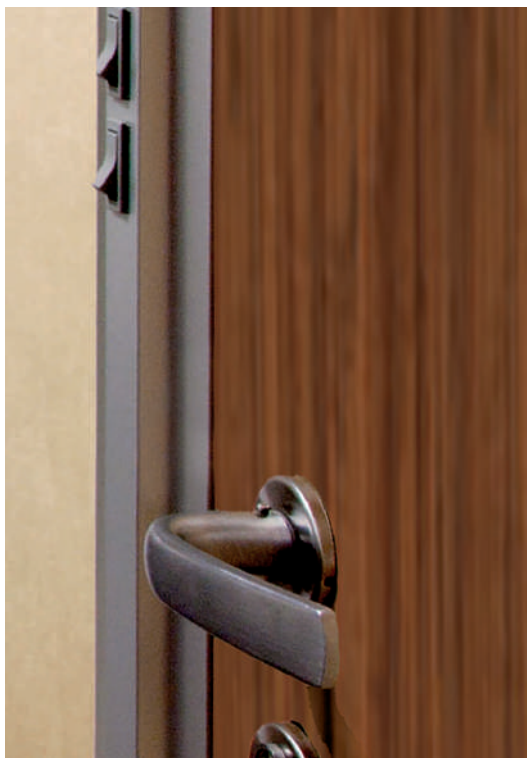















PERSPECTIVA



CORTES HORIZONTAIS

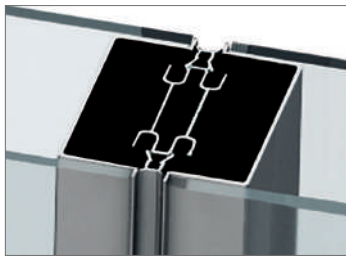
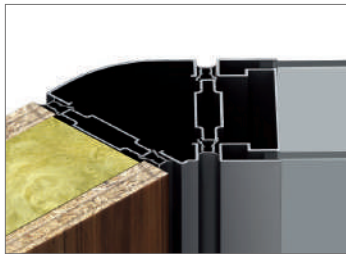
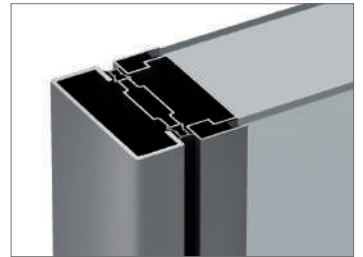
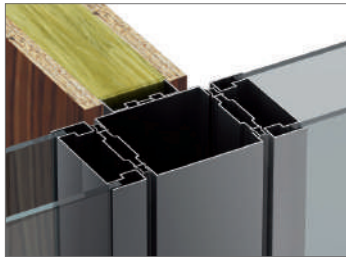

ISOLAMENTO ACÚSTICO

Módulo A

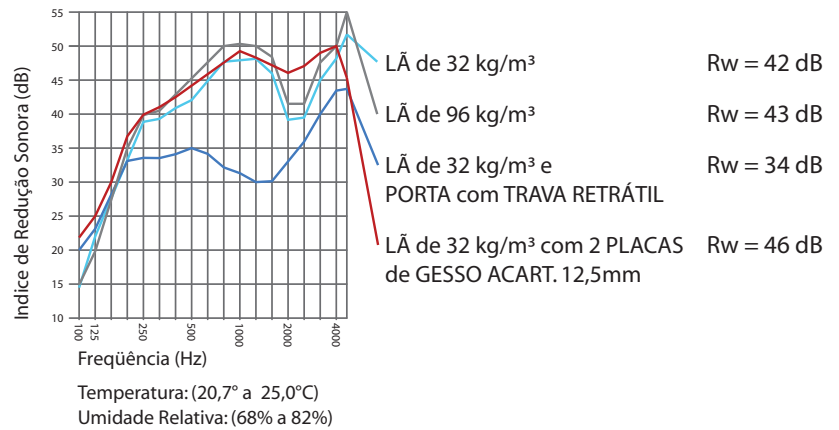
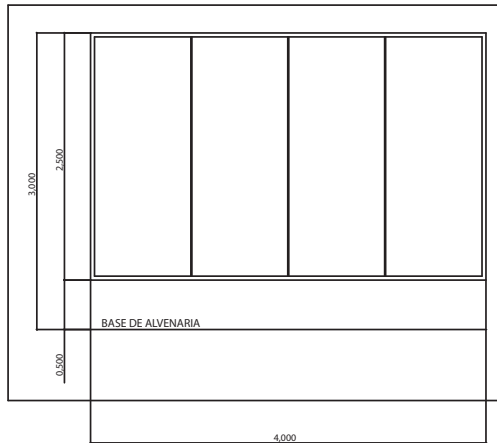

Módulo D

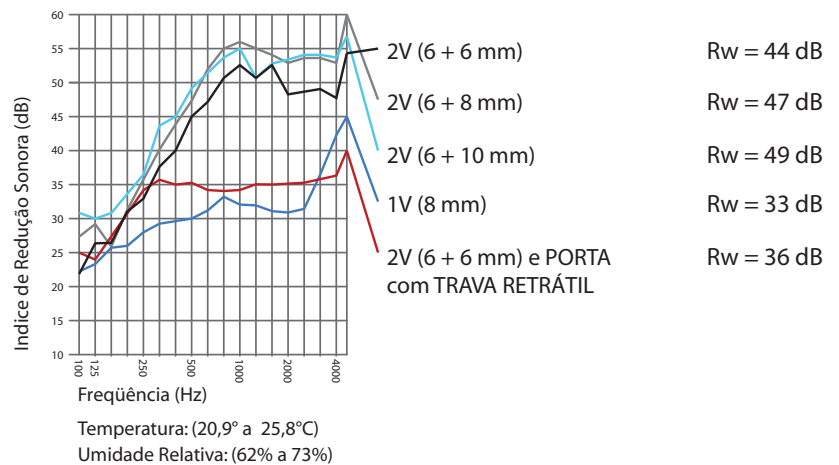
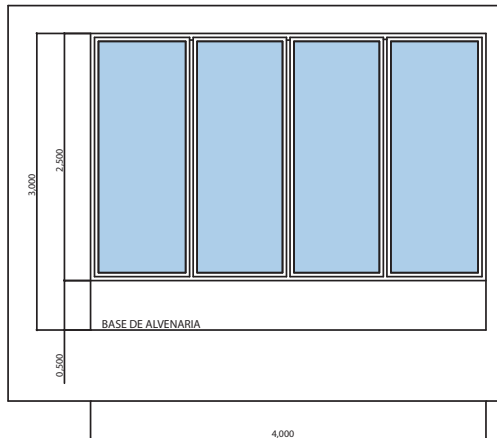

Módulo E

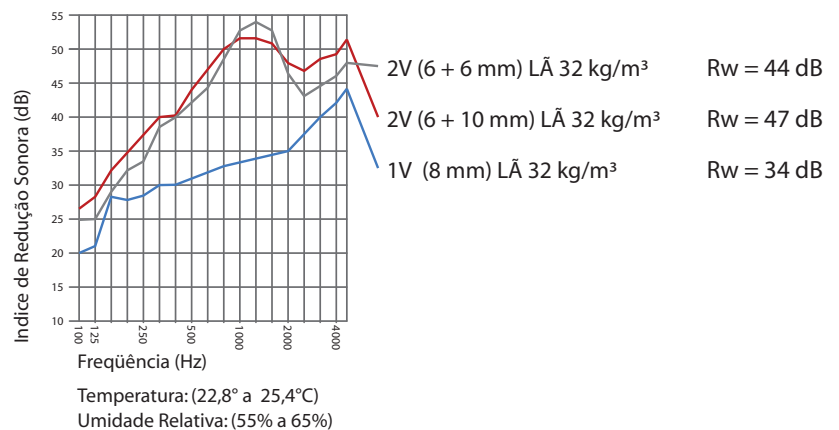
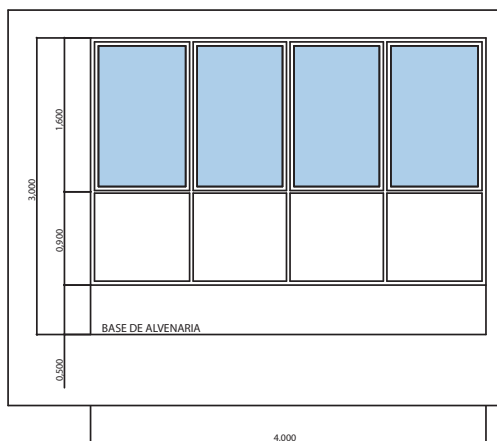

→ COTAS EM MILÍMETROS

Rw= Índice de Redução Sonora Ponderado (dB)
C= Coeficiente de Adaptação do Espectro para Ruído de Rosado
Ctr= Coeficiente de Adaptação do Espectro para Ruído de Trânsito

Solicite laudos completos dos ensaios

MÓDULOS

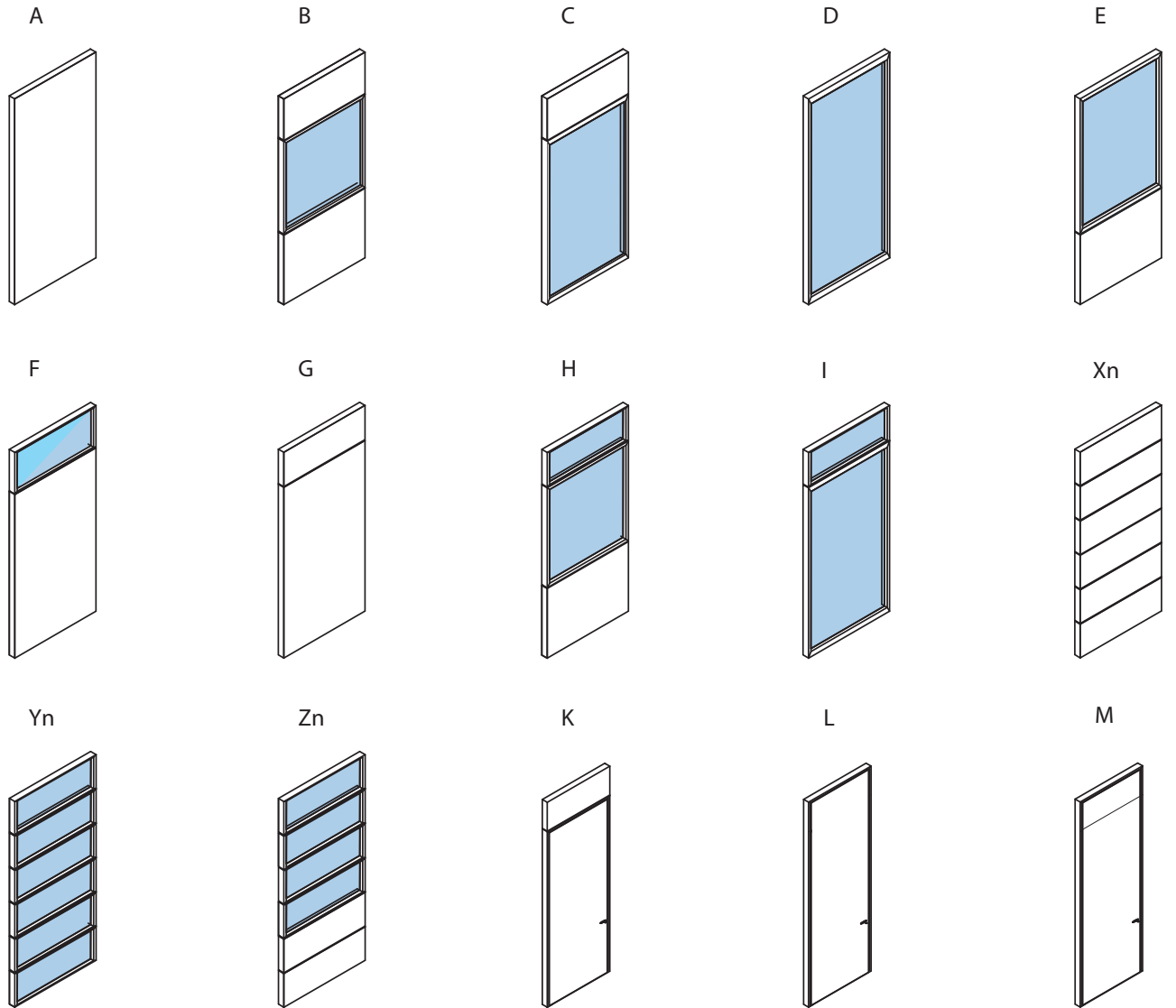

VARIAÇÕES PARA MÓDULOS DE PORTA

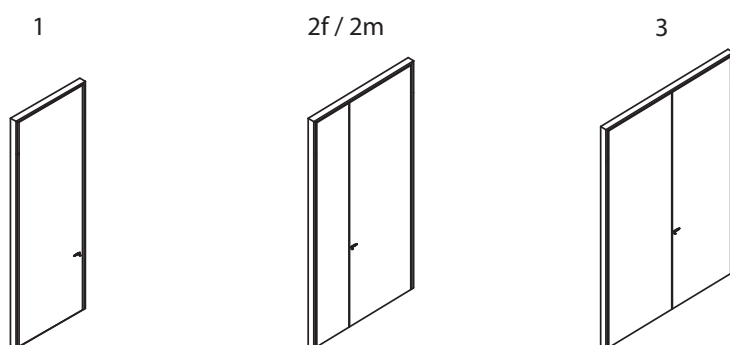



 ABATEX

Todas as imagens deste catálogo são meramente ilustrativas, não correspondendo necessariamente aos padrões de cores e texturas originais. As especificações técnicas podem ser alteradas sem aviso prévio. Consulte sempre nosso departamento comercial.



www.abatex.com.br
11 4186-9600
sac@abatex.com.br

